

NPA

November 2017

www.taegutec.com

New Product Announcement No. 2017-08

expansion

T-BURST HIGH PRESSURE

2mm T-BURST Tool Holder Expansion

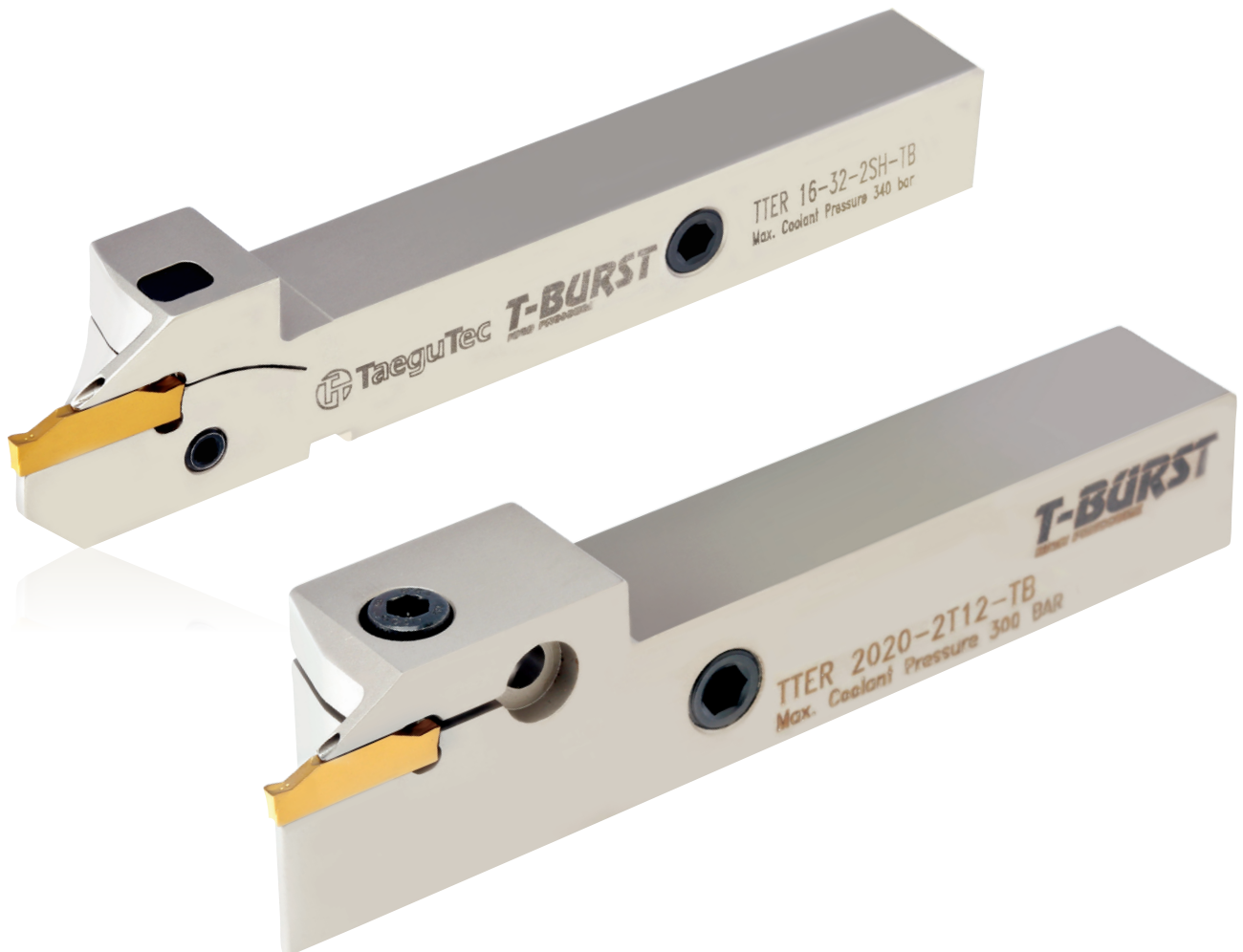

 **TaeguTec**
Member IMC Group

KEY POINT

The T-BURST's 2mm holder product line has been expanded to meet overwhelming demand due to its excellent performance and high productivity in grooving and parting of difficult-to-cut materials.

The newly added **2mm T-BURST** holders provide the same superior performance as the current line and are available for existing automatic Swiss lathe holders as well as general type holders.

Using the same efficient side-clamping method for tool mounting, users can easily change inserts in a matter of minutes. Also, the three coolant channels on both the right and left sides of the 2mm expansion holders means a steady coolant supply to both the cutting edge as well as the workpiece for effective cooling during machining.

This addition of **2mm T-BURST** holders enables superior machining solutions with improved tool life and higher productivity on difficult-to-cut materials.

All the new 2mm holders are interchangeable with the current 2mm inserts.

Availability

In stock

Price

Available in the GAL system

Sincerely,
TaeguTec

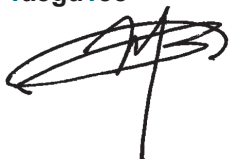

Park Hong-sik

Rotating & Non-Rotating Product Manager

Sincerely,
TaeguTec



Cha Byung-jae

T-Clamp & Threading Product Manager

T-BURST assembly guide

■ TTER/L-TB

High pressure coolant flow is supplied to the insert's cutting edge from the tool holder's internal coolant channel therefore allowing effective cooling, increased tool life while preventing built-up-edges.

* 2525 holder type (2020 holder type has 3 coolant inlets)

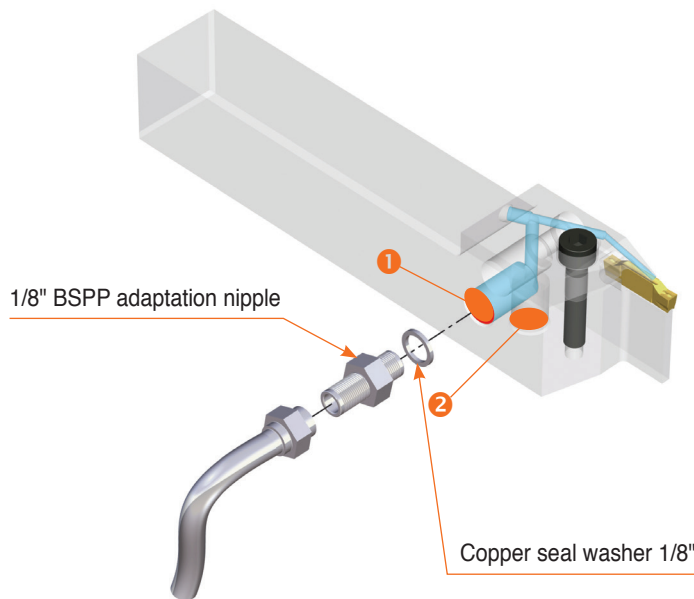

■ TTER/L-SH-TB

Designed with three coolant inlets, these holders are easily adaptable to different machine types and the side clamping design means convenient insert mounting.

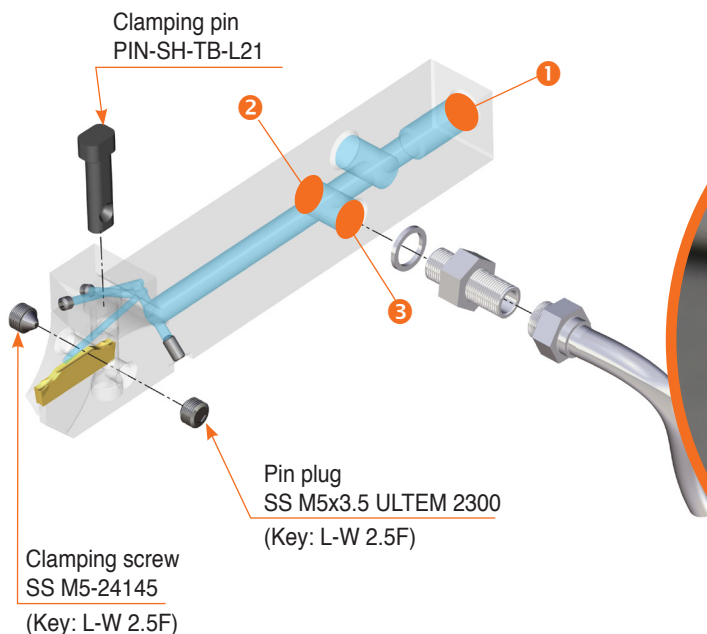

TTER/L-TB

Grooving and turning with channels for high pressure coolant

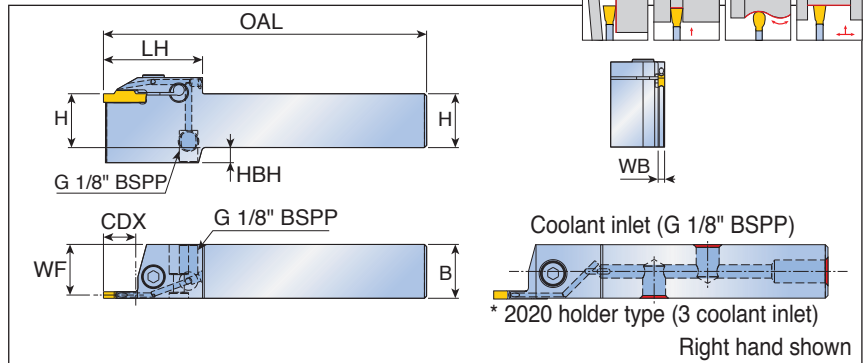
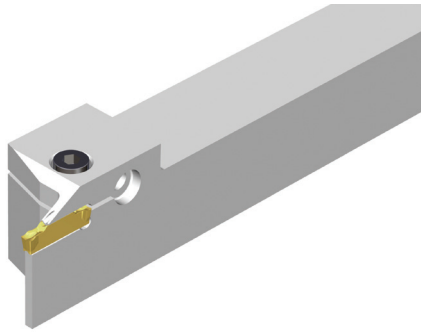

Designation	Insert seat size	Dimension (mm)								Torque (N.m)	Insert
		H	B	OAL	WF	LH	WB	HBH	CDX		
TTER/L 2020-2T12-TB new	2	20	20	125	19.1	43	1.8	-	12.0	5.5	TDC / J / T / A TDXU / XT TSC / J / A
2525-2T12-TB new	2	25	25	150	24.1	43	1.8	-	12.0	5.5	
2020-3-TB	3	20	20	125	18.8	43	2.4	-	12.0	5.5	
2020-4-TB	4	20	20	125	18.5	46	3.0	-	15.0	8.0	
2525-3-TB	3	25	25	150	23.8	43	2.4	-	12.0	5.5	
2525-4-TB	4	25	25	150	23.5	46	3.0	-	15.0	8.0	
2525-5-TB	5	25	25	150	23.1	49	4.0	-	20.0	8.0	
2525-6-TB	6	25	25	150	22.6	52	5.0	7	20.0	12.0	
2525-8-TB	8	25	25	150	22.1	58	6.0	7	25.0	12.0	

	70 bar flow rate (liters/min)	100 bar flow rate (liters/min)	140 bar flow rate (liters/min)
TTER/L 2020-2T12-TB	5-7	7-9	8-10
TTER/L 2525-2T12-TB	5-7	7-9	8-10
TTER/L 2020-3-TB	5-7	7-9	9-11
TTER/L 2020-4-TB	6-8	10-12	12-14
TTER/L 2525-3-TB	6-8	8-10	10-12
TTER/L 2525-4-TB	10-12	14-16	16-18
TTER/L 2525-5-TB	13-16	19-21	22-24
TTER/L 2525-6-TB	13-16	19-21	22-24
TTER/L 2525-8-TB	13-16	19-21	22-24

Spare parts

Designation	Screw	Wrench	Plug	Wrench for plug	
TTER/L 2020-2T12-TB	SH M5X0.8X20	L-W4	PLG G1/8-L6.5	L-W5	
TTER/L 2525-2T12-TB	SH M5X0.8X20	L-W4	PLG G1/8-T8.0-L12.3	L-W5	
TTER/L 2020-3-TB	SH M5X0.8X20	L-W4	PLG G1/8-L6.5	L-W5	
TTER/L 2020-4-TB	SH M6X1.0X20	L-W5	PLG G1/8-L6.5	L-W5	
TTER/L 2525-3-TB	SH M5X0.8X20	L-W4	PLG G1/8-T8.0-L12.3	L-W5	
TTER/L 2525-4 / 5-TB	SH M6X1.0X20	L-W5	PLG G1/8-T8.0-L12.3	L-W5	
TTER/L 2525-6 / 8-TB	SH M8X1.25X20	L-W6	PLG G1/8-T8.0-L12.3	L-W5	

TTER/L-SH-TB

Side lock holders with channels for high pressure coolant on Swiss type automatic machines

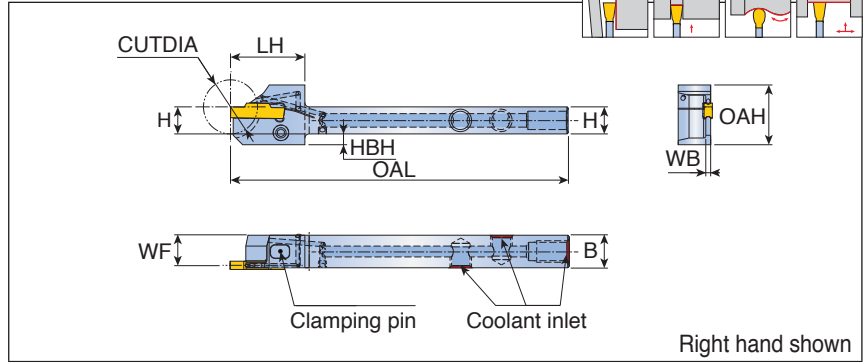
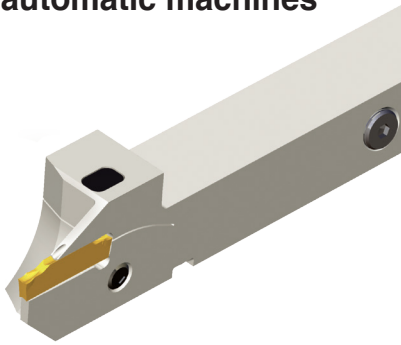

Designation	Insert seat size	Dimension (mm)										Coolant inlet	Insert
		H	B	OAL	WF	LH	WB	OAH	HBH	CUTDIA			
TTER/L 12-24-2SH-TB new	2	12	12	125	11.1	27.5	1.8	22.1	2	24	UNF 5/16	TDC / J / T / A TDXU / XT TSC / J	
16-32-2SH-TB new	2	16	16	125	15.1	31.5	1.8	24.1	-	32	UNF 5/16		
12-24-3SH-TB	3	12	12	125	10.8	27.5	2.4	22.1	2	24	UNF 5/16		
16-32-3SH-TB	3	16	16	125	14.8	31.5	2.4	24.1	-	32	UNF 5/16		

	70 bar flow rate (liters/min)	100 bar flow rate (liters/min)	140 bar flow rate (liters/min)
TTER/L-2SH-TB	5-7	7-9	8-10
TTER/L-3SH-TB	5-7	7-9	8-10

Spare parts

Designation	Clamping pin	Clamping screw	Pin plug	Wrench for clamping screw & pin plug	Inlet plug	Wrench for inlet plug
TTER/L...2SH-TB	PIN-SH-TB-L21	SS M5-24145	SS M5X3.5 ULTEM 2300	L-W 2.5F	PLG 5/16 UNF	L-W 5/32"
TTER/L...3SH-TB	PIN-SH-TB-L21	SS M5-24145	SS M5X3.5 ULTEM 2300	L-W 2.5F	PLG 5/16 UNF	L-W 5/32"